

ENFIS QUATTRO Mini Array Blue 465nm

The latest in ultra bright, chip on board, LED lattice arrays.
Compact, single colour spot source.

Features

Mounted array for simple incorporation

- Array mounted on connectorized PCB
- Drop-in capability into existing luminaires
- Incorporating thermal measurement device
- Designed for passive or active cooling

Densely packed lattice CoB array

- 144 LEDs in 4cm²
- Superior dynamic range
- Ultra bright output

High power useable light

- Drive to 200W
 - Potential for pulsing together with analogue and PWM dimming
- ### Rugged and proven
- Superior >20,000 hour lifetime
 - Reliable and repeatable performance operated in the harshest of environments

Inbuilt monitoring / control

- Potential for active monitoring and closed loop feedback and control of light output using integrated and calibrated photodiodes
- Inbuilt capability for temperature monitoring control and protection via integrated temperature sensors

PCB Arrays

Enfis can reduce the time, cost and risk of integration by offering purpose mounted ultra-bright multi-channel/colour arrays. These can be readily driven by appropriate drivers.

Smart Array Technology

Light output from Enfis Quattro-Mini arrays may be monitored and controlled via patent-pending integrated photo-detection system, enabling precise control and repeatable light output.

Thermal Management

Enfis Quattro-Mini arrays are designed to provide excellent thermal conductivity and integrate simply providing optimum performance and lifetime.

Optics

Enfis Quattro-Mini arrays provide a compact spot source with Lambertian emission characteristics. Enfis technical experts can advise a range of optical solutions to match your requirements.

Applications & Markets

- ◆ **Architectural lighting**
 - Exterior buried spotlights
 - Exterior floodlights
 - Exterior/interior wall-washing
- ◆ **Entertainment lighting**
 - Club/bar lighting
 - Theatre spot gel replacement
 - Moving spots
- ◆ **Fibre optic lighting**
 - Illuminator light sources
- ◆ **Medical Treatment**
 - Neo-natal/dermatological therapies
 - Dental treatment
- ◆ **Industrial/Scientific lighting**
 - Forensic investigation
 - Fluorescence and Spectroscopy
 - Machine Vision and inspection
 - Projection & backlighting systems
 - Vehicle lighting

The 4cm² Array
144 high-power LEDs



ENFIS QUATTRO Mini Array Blue 465nm

Technical Specification

Electro-Optical Characteristics

| Channel | Single Channel | | | All Channels | | |
|-----------------------------------------------------|----------------|------|-----|--------------|-------|-----|
| | Min | Typ | Max | Min | Typ | Max |
| Rated Current If (mA) | | 1550 | | | 6200 | |
| Forward Voltage Vf (Volts) | 28 | 32 | 36 | 28 | 32 | 36 |
| Peak Wavelength λp (nm) | 450 | 465 | 470 | 450 | 465 | 470 |
| Dominant Wavelength λd (nm) | 455 | 470 | 475 | 455 | 470 | 475 |
| Spectral Width Δλ (nm) | 15 | 23 | 30 | 15 | 23 | 30 |
| Total Radiant Flux ΦR (mW) | 5500 | 6900 | | 20000 | 24000 | |
| Radiant Flux Density ΦR/A (mW/cm ²) | 1136 | 1426 | | 3719 | 4545 | |
| Total Luminous Flux ΦL (Lumens) | 350 | 420 | | 1200 | 1450 | |
| Luminous Flux Density ΦL/A (lm/cm ²) | 72 | 87 | | 248 | 300 | |
| Total Electrical Power P (W) | | 50 | | | 200 | |

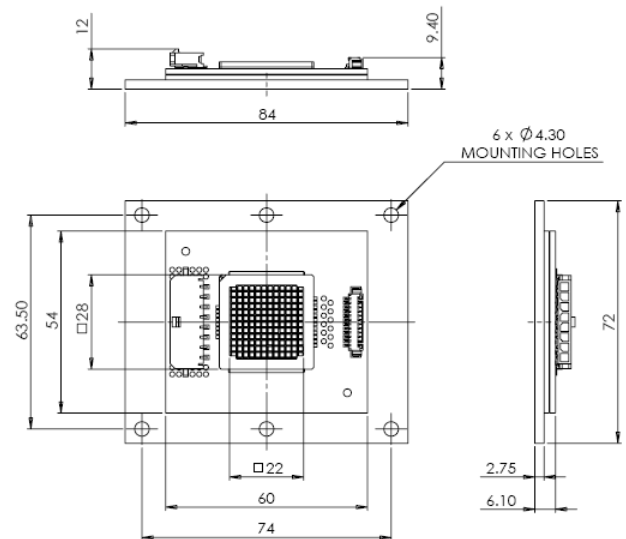

All measurements performed at a heatsink temperature of 25°C

LUMINOUS FLUX GRAPH

RADIANT FLUX GRAPH

IV GRAPH

Single Channel Data

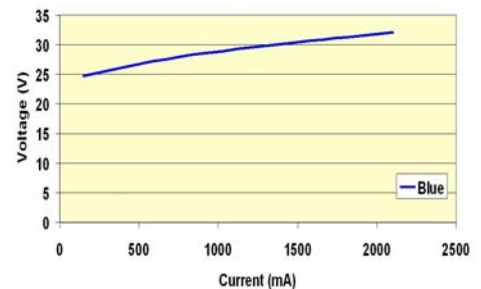
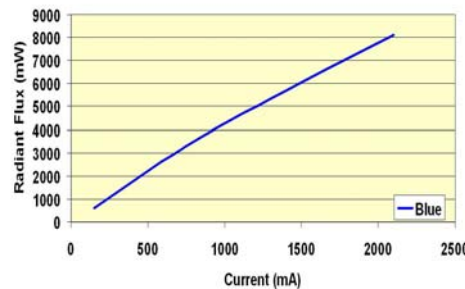
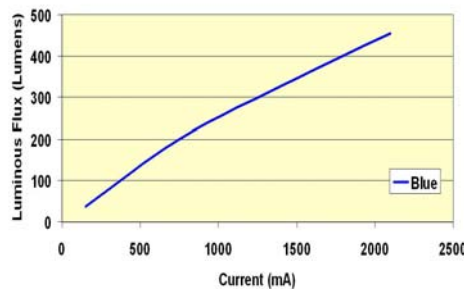

Storage Regime

Storage Temperature -20°C to +85°C

Weight

Array 0.2kg

Heat Generation

Proper thermal design of the end product is of paramount importance. The operational junction temperature of each LED chip should be kept below 125°C.

Please contact Enfis for further support in this matter.

Connector Types (not supplied)

Drive Molex 0436500812

Thermistor / Feedback Molex 532611271

Cleaning

Avoid touching the LED array surface.

To clean—BLOW surface with either dry air or nitrogen gas

Eye Safety Precautions

The light output of the products may cause injuries to human eyes in circumstances where the products are viewed directly with unshielded eyes for more than a few seconds.

Please refer to IEC 60825-1:2001 for further information



ENFIS LIMITED
Technium 2, Kings Road,
Swansea Waterfront,
Swansea, SA18PJ, UK
Tel +44 (0)1792 485660
Fax +44 (0)1792 485537
www.enfis.com
info@enfis.com

